

Two Bolt Cleat (Cast Iron)

370 Series

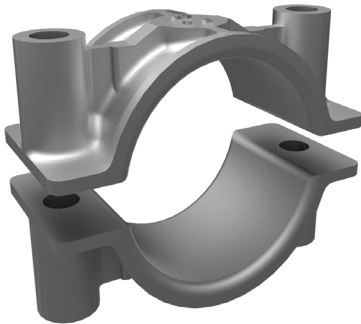

The cast iron two bolt cleat is an LUL approved cable cleat which can be applied to all types of cable routes. It can withstand high temperatures making it a first rate choice for fire performance cables.

Features and benefits

- Suitable for use with cable diameters 51 to 89mm.
- Hot dip galvanised finish on cast iron.
- Two-piece, two fixing design.
- Can be double stacked on common fixings.
- Operating temperature -60 °C to +105 °C.
- Can withstand a 2 hour excursion to 1000°C.
- Can be used for all types of cable routes.
- Suitable for all environments.
- LUL APR Product ID 1964
- Allows fire performance cables to meet the requirements of BS 8519:2020, BS 5266-1:2016, BS 5839-1:2017, BS 8491:2008 & BS 6387:2013

Performance Data

Test Standard	EN 50368:2003
Type	6.1.1 Metallic
Impact Resistance	6.2.5 V.Heavy
Lateral Load	3.7 -> 8.2 kN
Axial Load	1.332 -> 5.855 kN
Needle Flame	>120 secs

* Technical Information subject to change without notice

Technical Data

Cable and Cleat Selection			Cleats Details					
Design Number	Cable Diameter		Dimensions (mm)				Weight (g)	Stud size
	Min	Max	B	C	D	E		
370CG10	51	59	75	98	49	76	902	M10
370CG11	54	62	78	102	49	80	892	M10
370CG12	57	65	81	105	49	82	854	M10
370CG13	62	70	89	137	64	114	1155	M10
370CG14	68	76	95	140	64	114	1245	M12
370CG15	74	82	102	140	64	114	1300	M12
370CG16	80	89	108	140	64 <td 114	1582	M12	

Method of fixing

In all applications the cleats should be mounted on suitable fixings, see table for appropriate size. When mounting directly on channel, adaptor plate 380AG02 should be used.

* Technical Information subject to change without notice

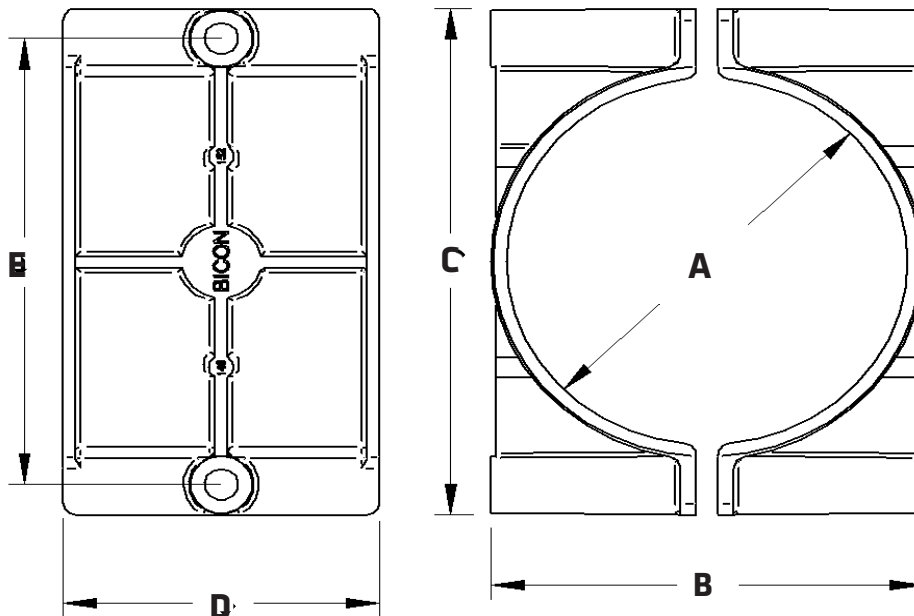

Prysmian Cables & Systems Limited,
Oak Road, Wrexham Industrial Estate, Wrexham, LL13 9PH, UK

Commercial Enquiries,
Sales Office Tel: 0845 767 8345,
International Sales Office Tel: +44 2380 295481

www.biconcomponents.co.uk